

K KONGSKILDE

BLOWERS
TRL /FRL/FEA

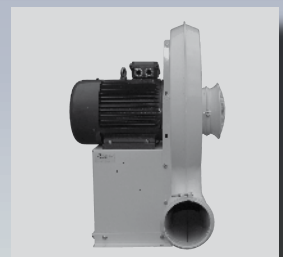

TRL/FEA/FRL

Kongskilde's FRL, FEA and TRL blowers constitute a range of proven conveying blowers, which are an ideal energy source for a vast number of industrial material handling systems.

The Kongskilde blowers are very suitable for a wide variety of applications, including air supply, conveying purposes, and ventilation where high pressure are required.

The blowers can be used for both suction- and blowing systems as well as suction-blowing-systems. But they are not intended for corrosive gases and the air temperature must not exceed 70°C.

Description

The aerodynamic shape of the Kongskilde blower ensures high efficiency and low energy consumption.

The blowers are designed as a centrifugal fan with a perfectly balanced rotor and thus a vibration-free operation, which minimises the noise level.

Pressure

FRL/FEA

Pressure total, P_t
kPa mm.WG.

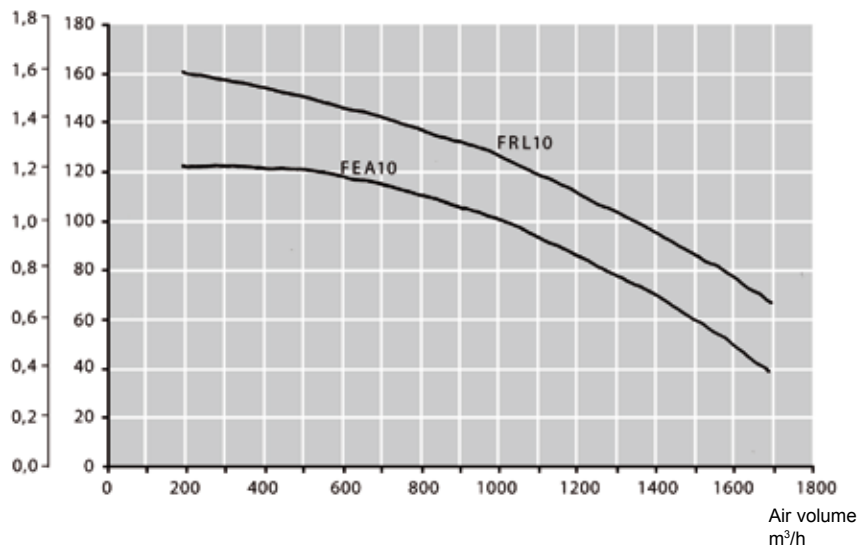

TRL

Pressure total, P_t
kPa mm.WG.

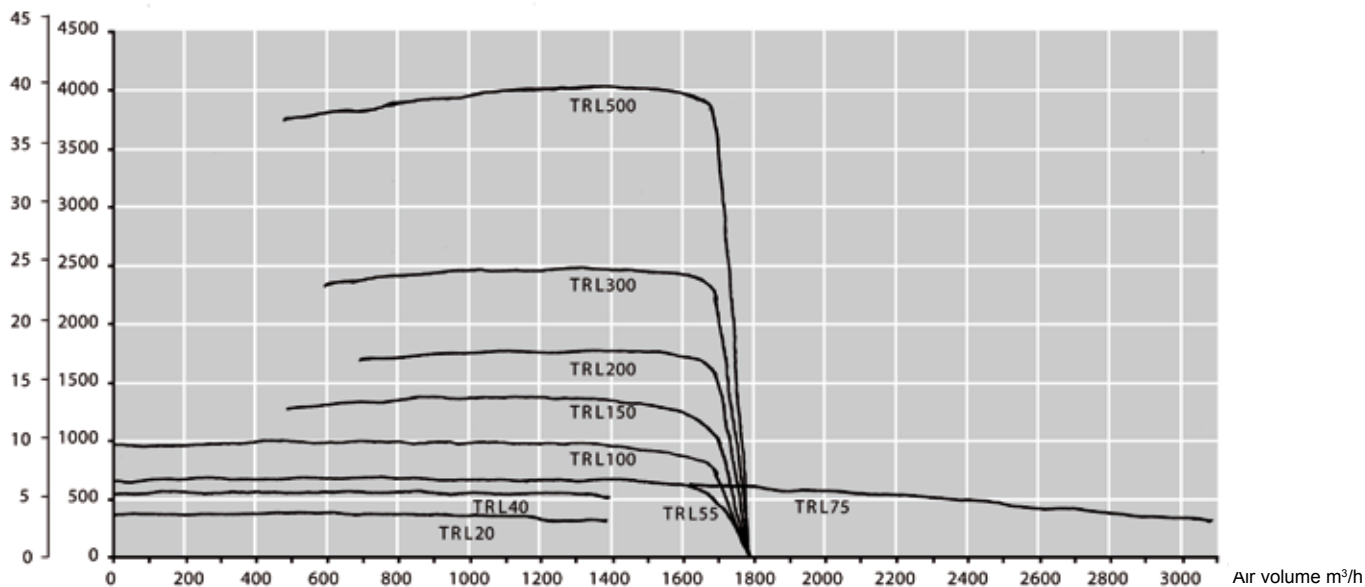

Air volume

The max. air volume delivered by the TRL blowers with air regulator is approximately 1800 m³/h at different pressures depending on the type of blower. It is a general rule in pneumatic conveying that the higher pressure in the system, the higher the transfer rate.

Application

FRL/FEA

Kongskilde's FEA 10 is a one-stage centrifugal blower with a closed rotor with 6 forward curved blades. It is particularly built for ventilation tasks. Suitable applications include suction of welding fume and gases.

FRL 10 is a one-stage centrifugal blower with an open rotor with 8 backward curved blades. Therefore, light material as e.g. plastic flakes can successfully be conveyed through the fan. The blower is at the same time very suitable for light dust and shavings exhaust purposes.

Both types (FRL/FEA) are available with and without motor.

TRL

The Kongskilde high-pressure blowers are available in a wide range of sizes – providing a variety of performance characteristics capable of meeting specific industrial requirements.

The TRL range with accessories is ideal for conveying of granular material and similar products with specific weight between 0.2 and 0.8 ton/m³. But they are also very suitable for most suction purposes e.g. suction of welding fume as well as to solve many ventilation tasks.

The small and medium-sized blowers are one-stage centrifugal blowers with closed rotors, whereas TRL 300 and 500 have two respectively three stages, which also are equipped with, closed rotors.

TRL 55/100/150/200/300 and 500 are equipped with air regulator. Combining the blower with an air regulator

optimises the conveying air speed by keeping the air velocity below 25 m/s, which minimises damage of the material even when conveying delicate materials. The constant air velocity does also prevent overloading of the motor and minimises the power consumption.

TRL20/40 can be used as either transport blower or suction blower whereas the TRL 55/75/100/150/200/300/500 can be utilised for both suction and blowing as well as they can be installed as a combination of a suction-blowing-system.

TRL 20/40/55/75

TRL 20/40/55/75 are directly driven.

TRL 20/40/75 are supplied with air intake mesh guards.

TRL 55 is supplied with automatic air regulator.

TRL 100/150/200

Within the TRL 100/150/200 blowers, pressure and air volume can always be adjusted to the purpose thanks to the ability of adjusting the rpm of the rotor. The blowers can be fitted with 7.5 to 15 kW motors, which have been adjusted to the rpm of the rotor.

The blowers are delivered with V-belt transmission.

TRL 300/500

The special advantage of the TRL 300/500 blowers is that they are capable of supplying an exceptional high pressure caused by the two- respectively three-step construction as each stage of the blower increases the air pressure.

Dimensions

FRL10/FEA10

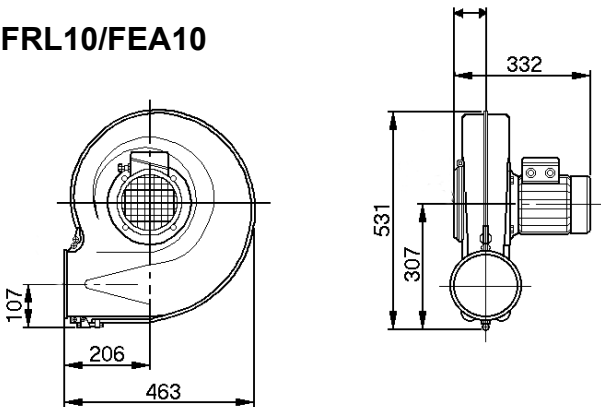

TRL20

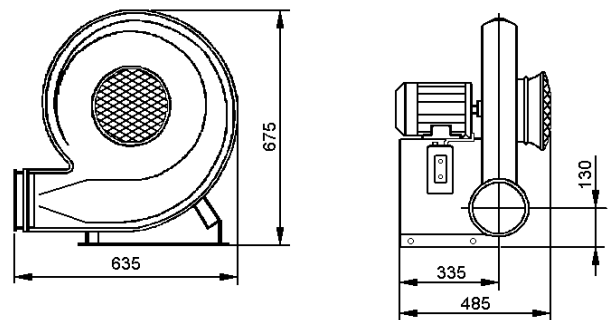

TRL40

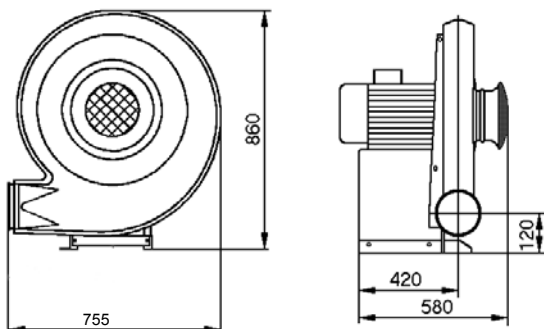

TRL55

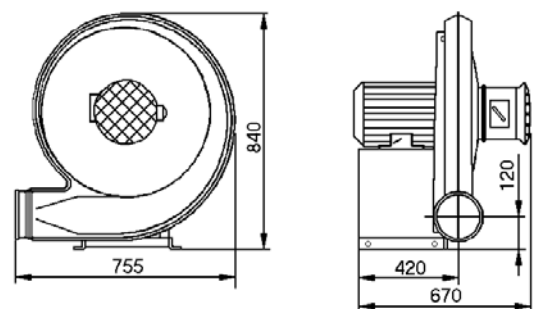

Dimensions

TRL75

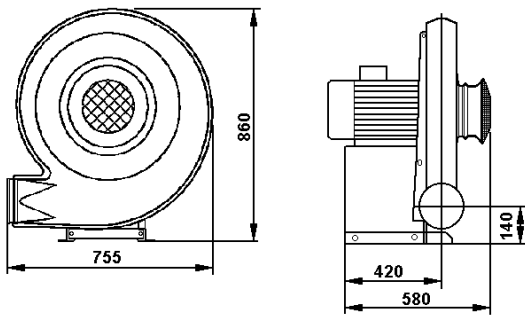

TRL100/150

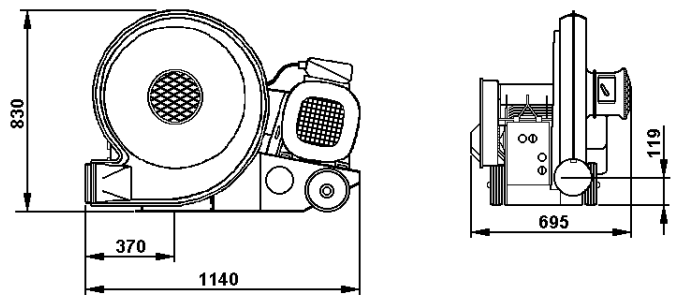

TRL200

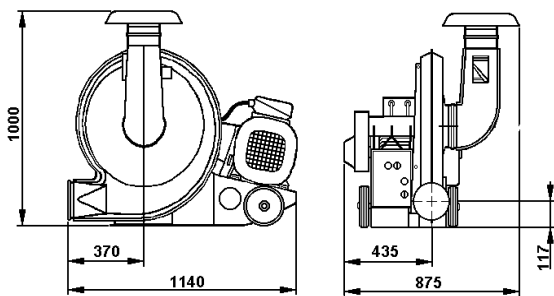

TRL300

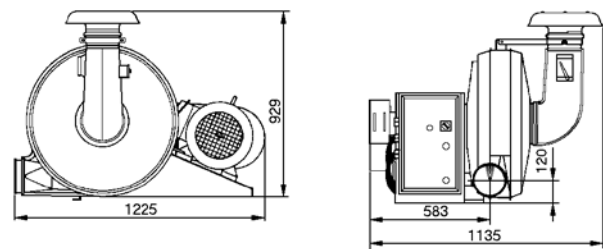

TRL500

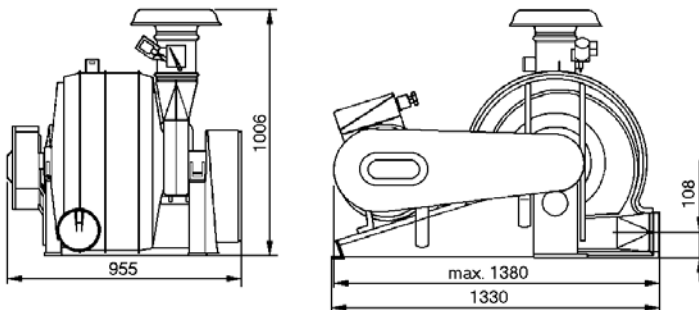

These drawings are based on our present technical knowledge. It is presented for information only and does not involve us in any commitment to supply.

All blower outlets are OK160.

Technical Data

	FRL 10	FEA 10	TRL 20	TRL 40	TRL 55	TRL 75
Motor rating, kW (Hp)	0,75 (1)	0,75 (1)	1,5 (2)	3 (4)	4 (5,5)	5,5 (7,5)
Motor rpm	2900	2900	2900	2900	2900	2900
Electrical supply, V/Hz	3 x 400 V, 50 Hz					
Amp. consumption	1,9	1,9	3,4	6,3	8,5	11,5
Min. fuse rating (approx.)	10	10	10	16	16	20
Rotor rpm	2900	2900	2900	2900	2900	2900
Weight w/o motor, kg	8,9	8,9	18	41	43	43
Weight w. motor, kg	21	21	35	67	76	96
Noise level, 1m distance dB (A)	76	76	83	82	91	85
Noise level, 7m distance dB (A)	61	61	64	64	77	71

	TRL 100	TRL 150	TRL 200	TRL 300	TRL 500
Motor rating, kW (Hp)	7,5 (10)	11 (15)	15 (20)	22 (30)	37 (50)
Motor rpm	2900	2900	2900	2900	2900
Electrical supply, V/Hz	3 x 400 V, 50 Hz				
Amp. consumption	15,5	21,5	29	41,5	69,5
Min. fuse rating (approx.)	25	35	50	63	100
Rotor rpm	3650	4200	4700	4100	4300
Weight w/o motor, kg	69	69	69	149	190
Weight w. motor, kg	129	157	195	324	468
Noise level, 1m distance dB (A)	90	97		93	93
Noise level, 7m distance dB (A)	73	81		78	80
V Belt	SPA-1600 raw edge 2 pcs ¹	SPA-1600 raw edge 2 pcs ¹	SPA-1600 raw edge 2 pcs ¹	SPA-1800 narrow 4 pcs ¹	SPA-1900 raw edge 3 pcs ¹

¹ Please note that all V-belts must be re-ordered in matched sets.

Inlets TRL 20/40/75

Kongskilde's TRL blowers can be equipped with a number of inlets suitable for various applications. The possible inlets are illustrated below.

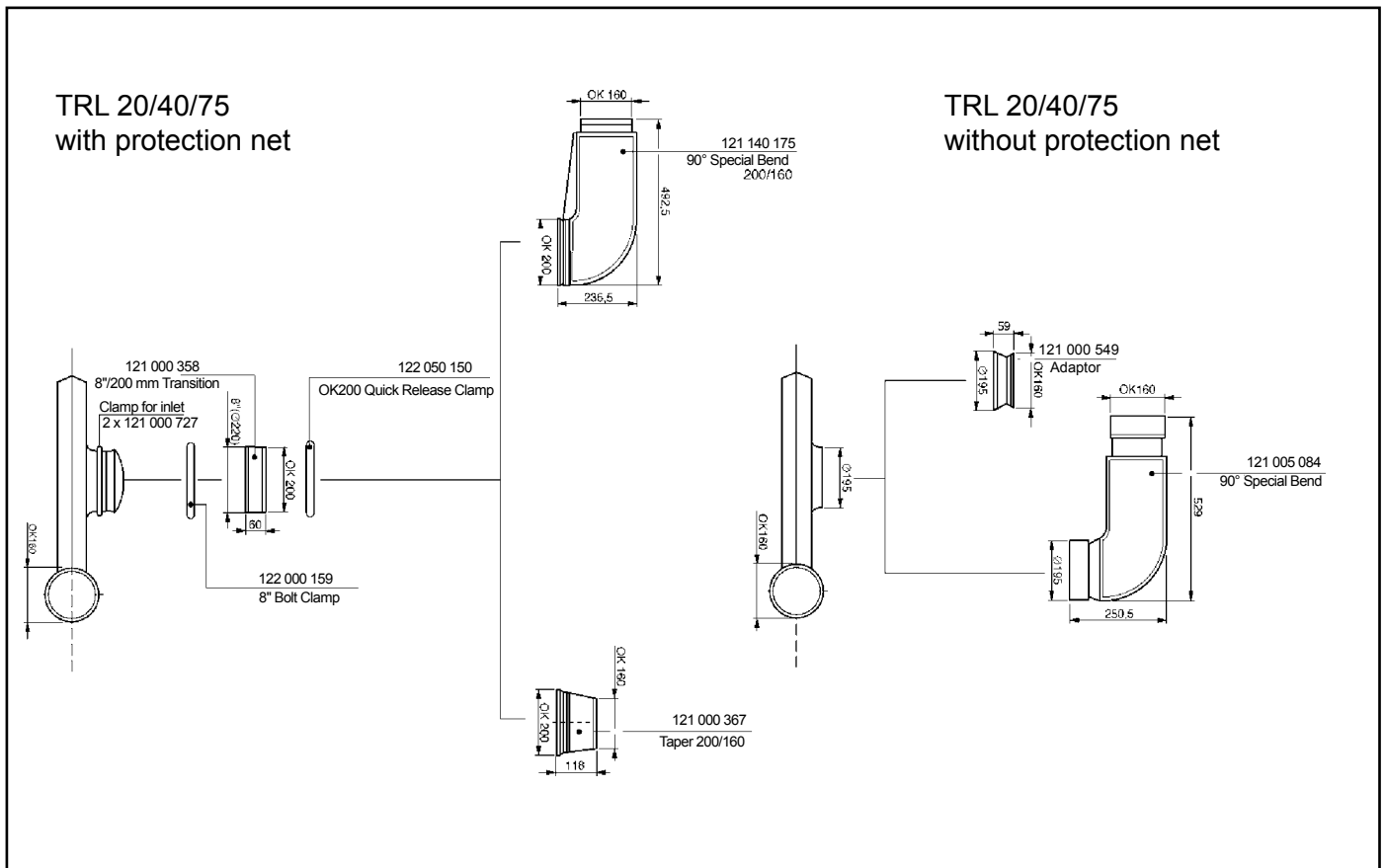

Inlets TRL 55/100/150

TRL 55, 100/150
With protection net
and air regulator

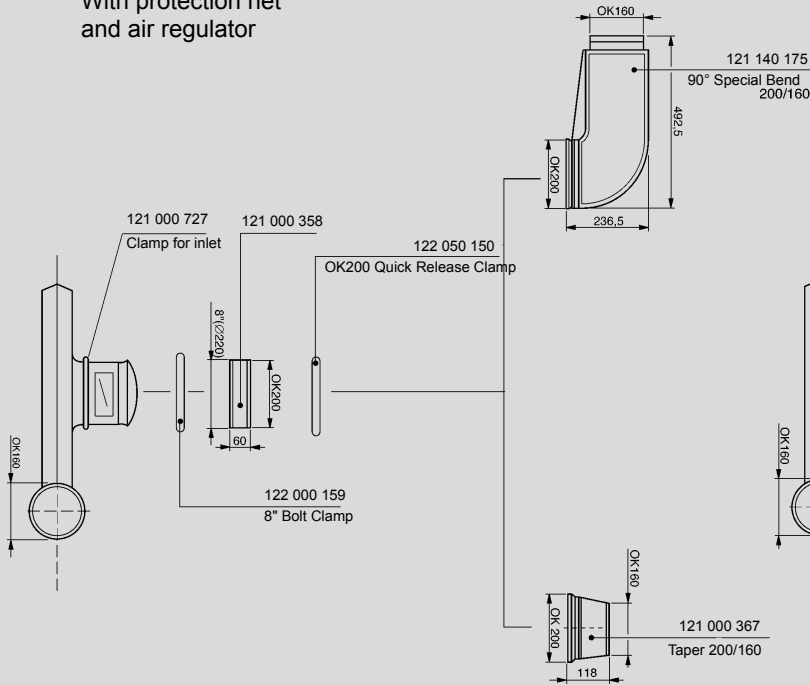

TRL 55, 100/150
without protection
net and air regulator.
Is normally not
recommended.

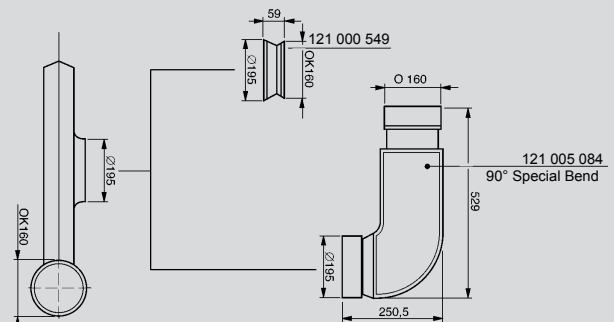

Standard Equipment

The Kongskilde blowers are as standard delivered with motor, protection IP 55, and closed rotor.

TRL 20/40/55/75/100 are as standard delivered with motor, protection IP 55, but they are also available without motor.

TRL 150/200/300/500 are as standard delivered with motor, protection IP 55, and automatic starter. But they are also available without motor.

Accessories

Kongskilde's product range includes an assortment of rotary valves, injectors, cyclones and a wide range of pipe components, suitable for combination with the blowers. Please see Kongskilde's data sheets for further information on the specific items.

The TRL blowers can be equipped with the illustrated inlets.

Options

All blowers are available with motors suitable for 60 Hz. Directly driven blowers is supplied with different rotor sizes to suit the 60 Hz rpm.

In- and outlet on the blowers can be connected to the Kongskilde OK-pipe system.

TRL 75 is available in stainless steel.



Kongskilde Industries A/S
Skælskørvej 64
DK-4180 Sorø • Denmark
Tel. +45 33 86 37 00 • Fax +45 33 68 86 24
mail@kongskilde.com
www.kongskilde.com